

BOT(N)yyyyZnn-19''

ULTRABROADBAND OPTICAL TRANSMITTER



Application

- ▶ Electrical to optical conversion of multi-channel CATV signals like AM-VSB, FM and QAM signals
- ▶ Downstream or upstream transmission in HFC networks
- ▶ BOT1550-19'', BOTDWnn-19'': SBS suppression and pre-chirping technology
- ▶ Ultra broad bandwidth of up to 5 ... 1000 MHz
- ▶ Dual RF inputs: low and high level inputs, optionally narrowcast input with high isolation

Features

- ▶ Low noise DFB laser with pre-distortion technology, 1310nm, 1550nm, CWDM and DWDM variants with different optical output power
- ▶ BOTDWnn-19'': ITU-Grid wavelength with adjustable wavelength: +/- 100 GHz
- ▶ Output powers between +3 and +15 dBm (+3 and +6 dBm with un-cooled lasers)
- ▶ All-electronically adjustments: slope, gain, output power, OMI, pre-chirping etc
- ▶ Automatic load control (ALC) for constant OMI_{toRMS}
- ▶ RS485 control interface
- ▶ SC/APC or E2000 connector as standard
- ▶ Very thin, only 1 RU design for mounting into 19'', ETSI or JIS racks

Block Diagram

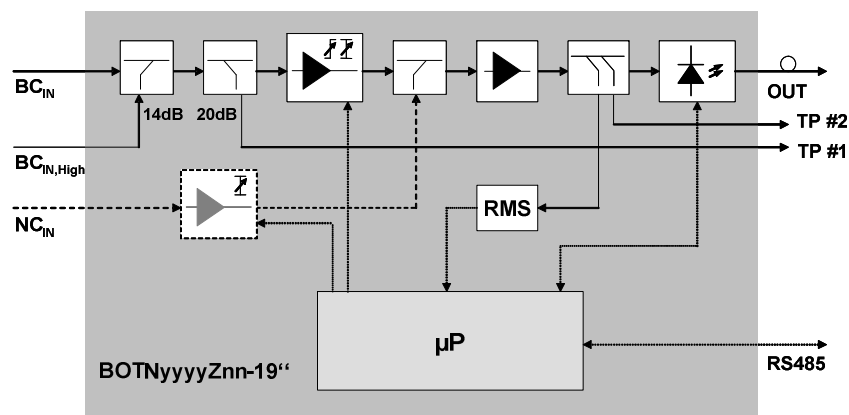

Available Types

S Type

BOT1310S03, S06-19''
 BOT1550S03, S06-19''
 BOTCW11S03 ... CW18S03-19''
 BOTCW11S06 ... CW18S06-19''

N Type

BOT1310N03-19''
 BOT1310N04-19''
 ...
 BOT1310N15-19''

L Type

BOTDW21L08, L11-19''
 BOTDW22L08, L11-19''
 ...
 BOTDW58L08, L11-19''

X Type

BOT(N)1310X03, X05, X08, X11, X13 and X14-19''
 BOT(N)1550X08-19''

Y Type

BOT(N)1310Y05, Y08, Y11, Y13 and Y14-19''

General Technical Data
BOT(N)YYYYZnn 19'' Mnemonic

Narrowcast input option N	BOT ... no additional narrowcast input NC _{IN} BOTN ... equipped with additional narrowcast input NC _{IN}
Wavelength yyyy	1310 and 1550 CWmm – CWDM laser (ITU grid channel number mm) DWmm – DWDM laser (ITU grid channel number mm)
Type Z	S – standard uncooled laser for return path applications L – linear cooled laser for forward path (narrowcast) applications N – standard linear cooled laser for forward path (broadcast) applications X – extremely linear cooled laser for forward path (broadcast) applications Y – super linear cooled laser for forward path (broadcast) applications
Optical output power nn	nn denotes output power in dBm

General Performance Data

	S Type	L Type	N Type	X and Y Type
Frequency range	5 ... 450 MHz	5 ... 1000 MHz	45 ... 862 MHz	5 ... 1000 MHz
Impedance	75 Ω			
Input level (OMI = 5%)	73 dBμV minimum for BC _{IN} (87 dBμV minimum for coupled input for BC _{IN,High})			
Gain adjustment	0 ... 24 dB			
Slope adjustment	-3 (cable equivalent) ... +16 dB (cable equalization)			
RF return loss	> 20 dB (at 47 MHz) - 1.5 dB/oct, min. 15 dB > 18 dB for 5 ... 65 MHz			
Input level for input NC _{IN} (OMI = 5%)	80 dBμV minimum for NC _{IN}			
Gain adjustment for narrowcast input NC _{IN}	0 ... 12 dB			
Isolation between BC _{IN} and NC _{IN}	> 50 dB			
Testpoint TP1 attenuation	20 dB			
Testpoint TP2 (AC voltage for RF signal and DC voltage for optical output power indication)	80 dBμV+2ΔP _{opt} ± 2.0 dB at OMI = 5% (AC) 0.1 V/mW ± 0.02 V/mW (DC)			
Optical output power adjustment	0 ... -3 dB			
Output power tolerance	1310 nm: 1550 nm:	±1.0 dB ±1.0 dB	– ±0.5 dB	±0.7 dB – ±0.5 dB -1.5 ... +1.5 dB
Optical wavelength fine tuning	–	-100...+100 GHz		–
Optical return loss	> 35 dB	> 45 dB	> 40 dB	> 45 dB
Power consumption	≤ 11.5 W	≤ 17 W	≤ 17 W	≤ 17 W
Dimensions of 19'' practice	483 x 240 x 45 mm (19'' / 1 HE)			
Weight	~2 kg			
Power supply	100 ... 240 VAC			

Safety, EMC, Environmental Conditions

Safety	EN 50 083-1 and EN 60 950 Laser Class 1M acc. IEC 60 825-1 (eyesafe for normal viewing)
EMC	EN 50 083-2
Equipment operation environmental conditions	Class 3.1 acc. ETS 300 019-1-3 (temperature controlled locations)

Transmission Performance Data

X, N, L Type Transmitter Performance

Version ccc, channel allocation plan	C42	B36	N77
Channel allocation plan (number of carriers)	Cenelec (42)	PAL B/G (36)	NTSC (77)
Optical modulation index OMI	4.1%	4.4%	3.0%
Noise bandwidth	5 MHz	5 MHz	4 MHz
CNR Y and X-Type (1310 nm) ^{1,2)}	≥ 51.5 dB	≥ 52.2 dB	≥ 51.2 dB
CNR X-Type (1550 nm) ¹⁾	≥ 51.0 dB	≥ 51.7 dB	≥ 50.7 dB
CNR N-Type (1310 nm) ³⁾	≥ 51.5 dB	≥ 52.2 dB	≥ 51.2 dB
CNR L-Type (1550 nm) ¹⁾	≥ 51.0 dB	≥ 51.7 dB	≥ 50.7 dB
CSO Y-Type (1310 nm) ^{1,2)}	≥ 68 dBc	≥ 70.5 dBc	≥ 69 dBc
CSO X-Type (1310 nm) ^{1,2)}	≥ 65 dBc	≥ 68.5 dBc	≥ 67 dBc
CSO X-Type (1550 nm) ^{1,4)}	≥ 60 dBc ⁵⁾	≥ 60 dBc	≥ 60 dBc
CSO N-Type (1310 nm) ³⁾	≥ 62 dBc	≥ 65 dBc	≥ 65 dBc
CSO L-Type (1550 nm) ^{1,4)}	≥ 52 dBc ⁵⁾	-	-
CTB Y-Type (1310 nm) ^{1,2)}	≥ 69 dBc	≥ 73 dBc	≥ 70 dB
CTB X-Type (1310 nm) ^{1,2)}	≥ 66 dBc	≥ 70 dBc	≥ 68 dB
CTB X-Type (1550 nm) ^{1,4)}	≥ 62 dBc	≥ 64 dBc	≥ 63 dB
CTB N-Type (1310 nm) ³⁾	≥ 66 dBc	≥ 70 dBc	≥ 68 dBc
CTB L-Type (1550 nm) ^{1,4)}	≥ 58 dBc	-	-
CXM Y and X-Type (1310 nm) ^{1,2)}	≥ 63 dBc	≥ 63 dBc	≥ 63 dBc
CXM X-Type (1550 nm) ^{1,4)}	≥ 55 dBc ⁵⁾	≥ 57 dBc	≥ 57 dBc
CXM N-Type (1310 nm) ³⁾	≥ 62 dBc	≥ 62 dBc	≥ 62 dBc

S Type Transmitter Performance

Laser RIN	≤ -145 dB/Hz (typical better -150 dB/Hz)
IM2 S-Type ⁷⁾	≥ 46 dBc (two tone with OMI= 20% per carrier)
IM3 S-Type ⁷⁾	≥ 54 dBc (two tone with OMI= 20% per carrier)

Test Conditions

- ¹⁾ Transmitters with 8 to 15 dBm optical output power: 20 km non-dispersion shifted fiber, optical attenuator and optical receiver with $P_{opt,in} = 0$ dBm, $I_{eq} = 7.0$ pA/√Hz and $\eta = 0.80 / 0.95$ A/W (at 1310 / 1550 nm) used
- ²⁾ Transmitters with 3 to 5 dBm optical output power: 6 km non-dispersion shifted fiber, optical attenuator and optical receiver with $P_{opt,in} = 0$ dBm, $I_{eq} = 7.0$ pA/√Hz and $\eta = 0.80 / 0.95$ A/W (at 1310 / 1550 nm) used
- ³⁾ No fiber, but optical attenuator and optical receiver with $P_{opt,in} = 0$ dBm, $I_{eq} = 7.0$ pA/√Hz and $\eta = 0.80 / 0.95$ A/W (at 1310 / 1550 nm) used
- ⁴⁾ 0-20 km non-dispersion shifted fiber, optical attenuator and optical receiver with $P_{opt,in} = 0$ dBm, $I_{eq} = 7.0$ pA/√Hz and $\eta = 0.95$ A/W used and fiber length (chirp) compensation adjustment set to optimum
- ⁵⁾ Only for measured frequencies up to 600 MHz, otherwise CSO value is 6 dB and CXM value is 2 dB lower!
- ⁶⁾ CXM measured according "C" method: CXM is the ratio between measurement carrier (lowest frequency carrier) and the side lobes arising when all other carriers (besides the meas. carrier) are 100% modulated with 15.625 kHz modulation frequency
- ⁷⁾ No fiber, optical receiver with $P_{opt,in} = 0$ dBm, $I_{eq} = 7.0$ pA/√Hz and $\eta = 0.95$ A/W (at 1550 nm) used