

BCA824

RF FORWARD/RETURN AMPLIFIER

Functional Description

- ▶ Flexible forward/return RF amplifier with high linearity for headend and hub locations
- ▶ Extremely broad frequency range
- ▶ Main and coupled input port
- ▶ RF gain and slope software configurable
- ▶ RF power detection
- ▶ (Load controlled) AGC option included and software configurable
- ▶ Output test port
- ▶ 1:2 RF Splitter/combiner for input or output port
- ▶ Standby mode with reduced power consumption
- ▶ RS 485 remote supervision and control interface for management purposes
- ▶ BK mechanics with module width 1 and BK compliant powering

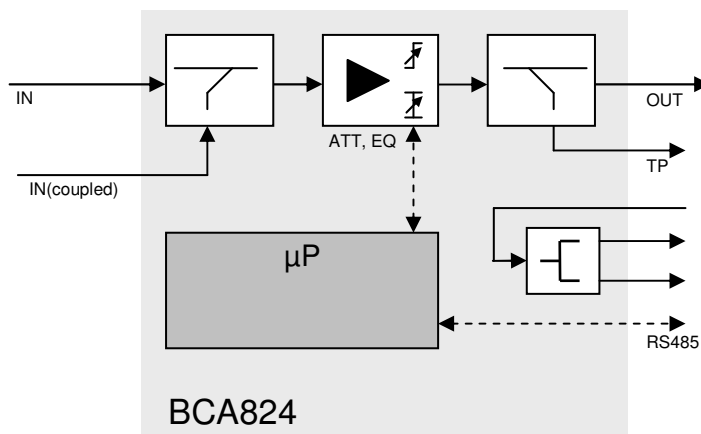

Technical Data

Frequency range	5 ... 1000 MHz
Frequency response	
5 ... 7 MHz	-1.5 ... +0.8 dB
7 ... 47 MHz	±0.8 dB
47 ... 606 MHz	±0.5 dB
606 ... 870 MHz	±0.8 dB
870 ... 1000 MHz	±1.5 dB
Input level of coupled input	+14 dB referred to main input port
Gain range	0 ... 24 dB
Slope range	0 ... 16 dB
Impedance	75 Ω
Return loss	
5 ... 65 MHz	≥18 dB
47 ... 870 MHz	≥18 dB (@47MHz) – 1 dB/oct. (minimum 15 dB)
Noise figure (max. gain, slope 0 dB) 5 ... 870 MHz	≤ 8 dB (typical 6.5 dB)
Output level for Cenelec 42 channel allocation (CSO ≥ 60 dB, CTB ≥ 60 dB)	106 dBμV, flat (no slope)
Nonlinearity for BK450 channel allocation at 93 dBμV, flat (34x PAL at 93dBμV, 14x 256QAM at -6dB, 36x FM at -4dB)	CSO ≥ 74 dB CTB ≥ 78 dB
CXM for Cenelec 42 channel allocation at 106 dBμV (24dB gain, low-noise mode)	≥ 62 dB (according C method of German Telecom) ≥ 56 dB (according Cenelec)
Test port attenuation	20 dB ±1 dB referred to output port
1:2 splitter loss	
5 ... 65 MHz	3.7±0.3 dB
47 ... 606 MHz	3.7±0.3 dB
606 ... 870 MHz	3.7±0.5 dB
Power consumption	
Operation	≤ 9 W
Standby	≤ 1 W
Dimensions of BK equipment practice	Module width 1
Weight	~1.1 kg